

NOTES:

REF. BUL. 100 & T-103 FOR THE FOLLOWING:

- b - ACCURACY CODE
- e - POINTER TYPE
- f - DIAL TRIM
- gg - PRESSURE RANGE CODE (T-103)
- h - CASE COLOR
- i - FITTING LOCATION
- j - FITTING TYPE
- k - ADDITIONAL OPTIONS

REVISIONS				
ZONE	REV	DESCRIPTION	DATE	APPROVED

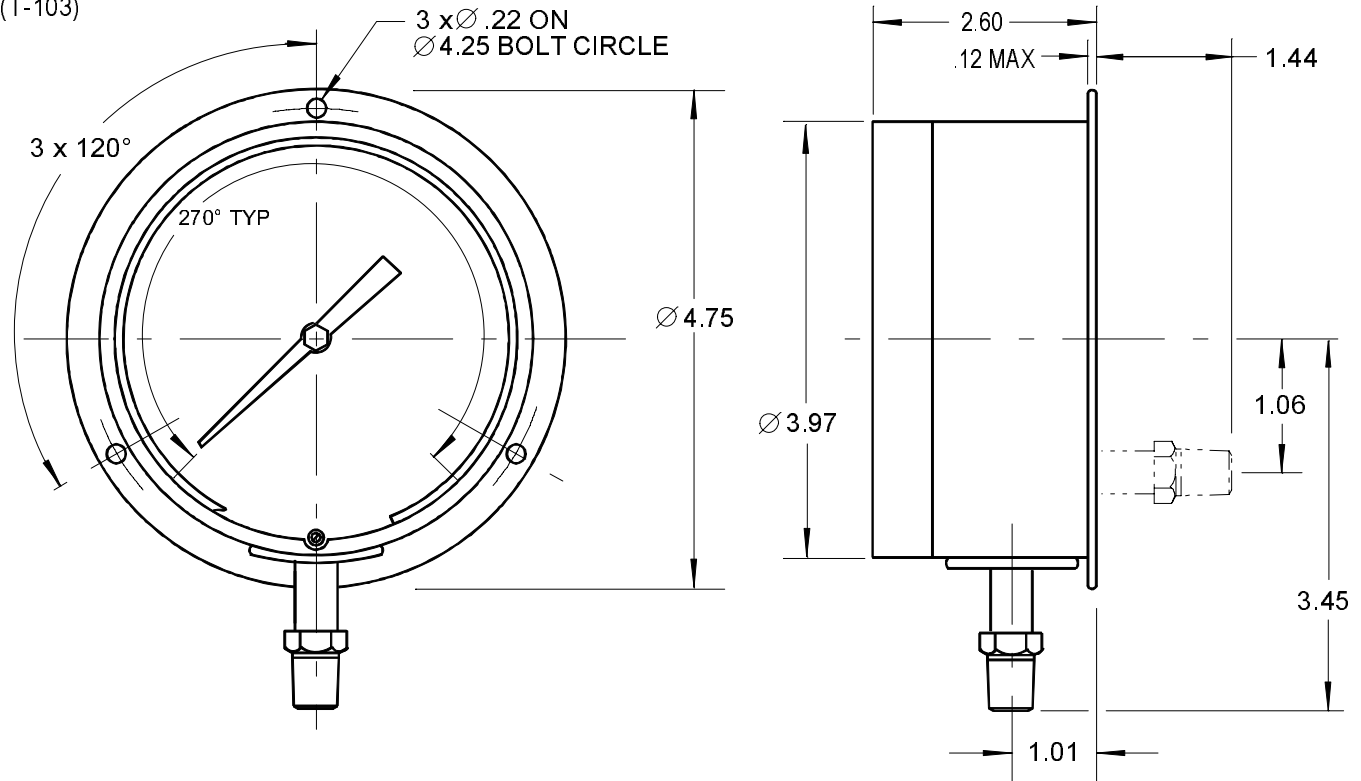

UNLESS OTHERWISE SPECIFIED DIMENSIONS ARE IN INCHES		MATERIAL: ALUMINUM		CONTRACT NO.		PERMA-CAL INDUSTRIES, INC.				
ANGULAR ± 1° LINEAR .XX ± .030 .XXX ± .015 FRACTIONAL ± 1/16		FINISH: POWDER COAT		PREP BY	PAL					DATE
DIAMETERS ON SAME C/L RUNOUT WITHIN <u>.016</u> FIR		USED ON: INDUSTRIAL / MIL-G GAUGES		CHECK			SIZE	CODE IDENT NO.	DRAWING NO.	REV
✓ SURFACE ROUGHNESS USAS B46.1		FILE NAME: 1b2Refgghij-Z		PROJ ENGR			A	59018	1b2Refgghij-Zk	N/C
SCALE NONE				WEIGHT		SHEET 1		OF 1		